



NORTH CAROLINA SENIOR GAMES

VIRTUAL BASKETBALL SHOOTING

SCORESHEET & PROCEDURES

= Miss (zero points)

= Successful Shot (1 point)

Shot 1 Lay up (either side)	Shot 2 9' shot (from the center of the basket)	Shot 3 Free Throw (15' from the backboard)	Shot 4 6' shot (from the center of the basket)	Shot 5 10' shot (from the center of the basket)	Shot 6 Top of Circle (19' 9" from the center of the basket)	Total
□□□	□□□	□□□	□□□	□□□	□□□	

Court

- The basket will be 10 feet in height.
- The court will be designed, as in the diagram given, to accurately reflect distances from the basket to the shooting lines.
- Measurements made for the free throw made from the backboard. All other measurements are made from the center of the basket (use a plumb line or pole to locate that point on the floor) to the inside edge of the **2-inch** tape lines.

Court Diagram

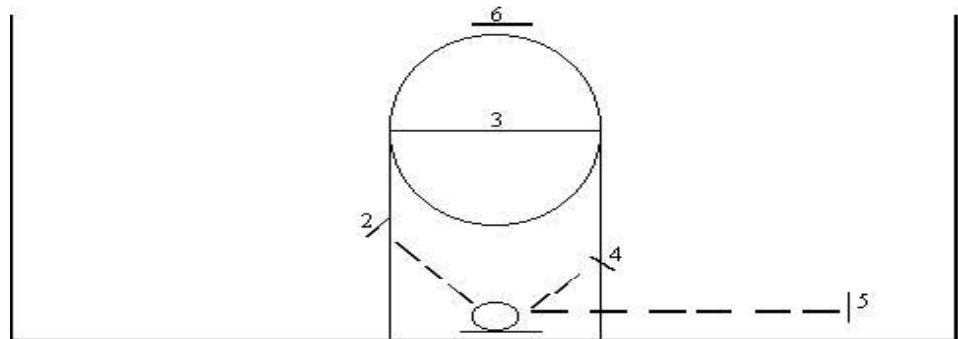

Equipment

All participants may use either the men or women's regulation basketball. Participants may use their own properly inflated basketballs.

The Game

- The players will shoot 3 shots from each of 6 designated areas of the court for a total of 18 shots (see diagram).
- Each shooter will be allowed 6 practice shots and 18 official shots. Participants may elect to "pass" any practice or official shot(s). Each shooter may use their first 6 shots as practice shot(s) or "pass on practice shot(s)". Participants must clearly state that they are "passing" on practice shot(s) or the first 6 shot(s) will be considered practice shot(s). The shooter must be behind the designated line (no part of his/her feet can touch on or beyond the line until the ball leaves his/her hands). Shoes are required.
- The lay-up may be taken from **EITHER** side of the basket (the only fault on the lay-up is a miss, and the participant may shoot from a stationary position OR moving). All other shots must be from the designated lines.